

# TOSHIBA

## MANUAL

# CCD COLOR CAMERA

# ***IK-645A***

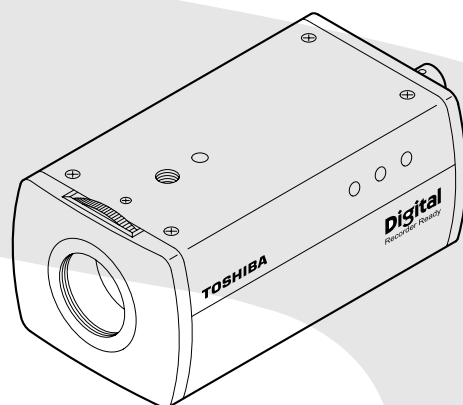

**CONTENTS**

**SECTION 1  
GENERAL DESCRIPTION**

(IK-645A)

1. FEATURES & DESCRIPTION .....	1-14
2. COMPONENTS .....	1-14
3. PART NAMES & FUNCTIONS .....	1-14
4. CONNECTIONS AND OPERATIONS .....	1-15
5. LENS .....	1-16
6. LINE-LOCK PHASE .....	1-16
7. MENU-DRIVEN SET-UP .....	1-16
8. NOTES ON USE AND INSTALLATION .....	1-19
9. IN CASE OF PROBLEMS .....	1-20
10. EXTERIOR VIEW .....	1-20

---

---

---

---

**SECTION 5  
SPECIFICATIONS**

1. SPECIFICATIONS .....	5-1
-------------------------	-----

## IMPORTANT SAFEGUARDS

### 1. Read Instructions

All the safety and operating instructions should be read before the product is operated.

### 2. Retain Instructions

The safety instructions and instruction manual should be retained for future reference.

### 3. Heed Warnings

All warnings on the product and in the instruction manual should be adhered to.

### 4. Follow Instructions

All operating and use instructions should be followed.

### 5. Cleaning

Disconnect this video product from the power supply before cleaning.

### 6. Attachments

Do not use attachments not recommended by the video product manufacturer as they may cause hazards.

### 7. Water and Moisture

Do not use this video product near water-for example, near a bath tub, wash bowl, kitchen sink, or laundry tub, in a wet basement, or near a swimming pool and the like.

### 8. Accessories

Do not place this video product on an unstable cart, stand, tripod, bracket or table. The video product may fall, causing serious injury to a child or adult, and serious damage to the product. Use only with stand, tripod, bracket, or table recommended by the manufacturer, or sold with the video product. Any mounting of the product should follow the manufacturer's instructions, and should use a mounting accessory recommended by the manufacturer.

### 9. Ventilation

This video product should never be placed near or over a radiator or heat register. This video product should not be placed in a built-in installation such as a bookcase or rack unless proper ventilation is provided or the manufacturer's instructions have been adhered to.

### 10. Power Sources

This video product should be operated only from the type of power source indicated on the marking label. If you are not sure of the type of power supply to your location, consult your product dealer.

### 11. Power-Cord Protection

Power-Supply cords should be routed so that they are not likely to be walked on or pinched by items placed upon or against them, paying particular attention to cords at plugs, screws and the point where they exit from the product.

### 12. Lightning

For added protection for this video product during a lightning storm, or when it is left unattended and unused for long periods of time, unplug it from the wall outlet and disconnect the power supply and cable system. This will prevent damage to the video product due to lightning and power-line surges.

### 13. Overloading

Do not overload power supply and extension cords as this can result in a risk of fire or electric shock.

### 14. Object and Liquid Entry

Never push objects of any kind into this video product through openings as they may touch dangerous voltage points or short-out parts that could result in a fire or electrical shock. Never spill liquid of kind on the video product.

### 15. Servicing

Do not attempt to service this video product yourself as opening or removing covers may expose you to dangerous voltage or other hazards. Refer all servicing to qualified service personnel.

### 16. Damage Requiring service

Disconnect this video product from the power supply and refer servicing to qualified service personnel under the following conditions.

- a. when the power-supply cord or plug is damaged.
- b. If liquid has been spilled, or objects have fallen into the video product.
- c. If the video product has been exposed to rain or water.
- d. If the video product does not operate normally by following the operating instructions in the instruction manual. Adjust only those controls that are covered by the instruction manual as an improper adjustment of other controls may result in damage and will often require extensive work by a qualified technician to restore the video product to its normal operation.
- e. If the video product has been dropped or the cabinet has been damaged.
- f. When the video product exhibits a distinct change in performance-this indicates a need for service.

### 17. Replacement Parts

When replacement parts are required, be sure the service technician has used replacement parts specified by the manufacturer with the same characteristics as the original part. Unauthorized substitutions may result in fire, electric shock or other hazards.

### 18. Safety Check

Upon completion of any service or repairs to this video product, ask the service technician to perform safety checks to determine that the video product is in proper operating condition.

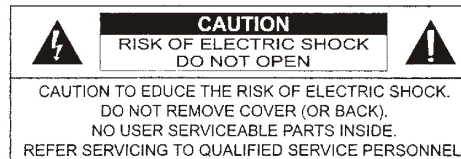

- The CAUTION label, shown on the left, is attached on the bottom of camera.



The lightning flash with arrowhead symbol, within an equilateral triangle, is intended to alert the user to the presence of uninsulated "dangerous voltage" within the product's enclosure that may be of sufficient magnitude to constitute a risk of electric shock to persons.



The exclamation point within an equilateral triangle is intended to alert the user to the presence of important operating and maintenance (servicing) instructions in the literature accompanying the appliance.

**WARNING :**  
TO REDUCE THE RISK OF FIRE OR ELECTRIC SHOCK, DO NOT EXPOSE THIS APPLIANCE TO RAIN OR MOISTURE.

**CAUTION**  
CONNECT 24V AC UL LISTED CLASS 2 POWER SUPPLY.

**FIELD INSTALLATION MARKING :**  
WORDED : "THIS INSTALLATION SHOULD BE MADE BY A QUALIFIED SERVICE PERSON AND SHOULD CONFORM TO ALL LOCAL CODES."

**INFORMATION**  
This equipment has been tested and found to comply with the limits for a Class A digital device, pursuant to Part 15 of the FCC Rules. These limits are designed to provide reasonable protection against harmful interference when the equipment is operated in a commercial environment. This equipment generates, uses, and can radiate radio frequency energy and, if not installed and used in accordance with the instruction manual, may cause harmful interference to radio communications. Operation of this equipment in a residential area is likely to cause harmful interference in which case the user will be required to correct the interference at his own expense.

**USER-INSTALLER CAUTION :** Your authority to operate this FCC verified equipment could be voided if you make changes or modifications not expressly approved by the party

## 1. FEATURES & DESCRIPTION :

1. IK-645A has following functions.

- (1) Since this camera uses AC 24V ~ / DC 12V ≐ , it can be installed and built into system easily.
  - (2) The settings and adjustments are made by way of on-screen menu. (Menu Driven Set-Up)
  - (3) This camera turns color by day to black and white by night automatically. (DAY/NIGHT function)
  - (4) Camera synchronization mode is selectable between internal and line-lock.
  - (5) This camera adjusts shutter speed according to the subject brightness automatically. (AES)
  - (6) BLC is effective when a strong light enters and auto-iris lens closes.
  - (7) The white balance is automatically adjusted corresponding to the color temperature variations (AWB)
  - (8) Easy back focus adjustment makes for easy installations.
2. Built - in 1/3 inch high - resolution CCD.
  3. Minimum illumination of 0.2 lux at F1.2.(GAIN : wide)
  4. S/N ratio of 50dB.
  5. Horizontal resolution of 480 TV lines.

## 2. COMPONENTS :

- |                        |   |                  |
|------------------------|---|------------------|
| (1) Camera             | 1 |                  |
| (2) Accessories        |   |                  |
| (a) Lens Connector     | 1 | (E4-191J-100(M)) |
| (b) Instruction Manual | 1 |                  |
| (c) Lens Cap           | 1 |                  |

## 3. PART NAMES & FUNCTIONS :

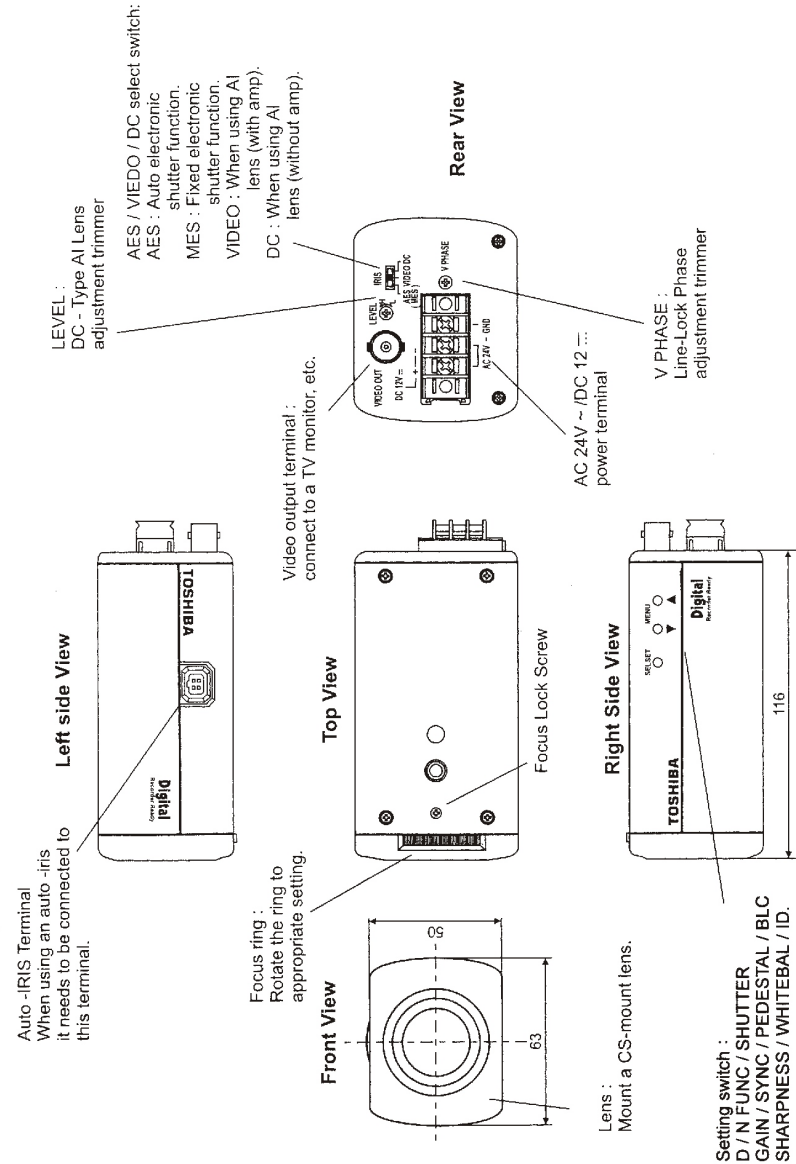

## 4. CONNECTIONS AND OPERATIONS

### Notes on connecting

- Power plugs of connected equipment must be disconnected before installations.
- A 75-ohm coaxial cable (3C-2V or 5C-2V) is required for standard connection.
- For details of wiring and operation of equipment to be connected, refer to their operation manuals.
- Lenses, coaxial cables for video signals and the power cord are not supplied with the camera.

### 4-1. Basic connection Single system configuration

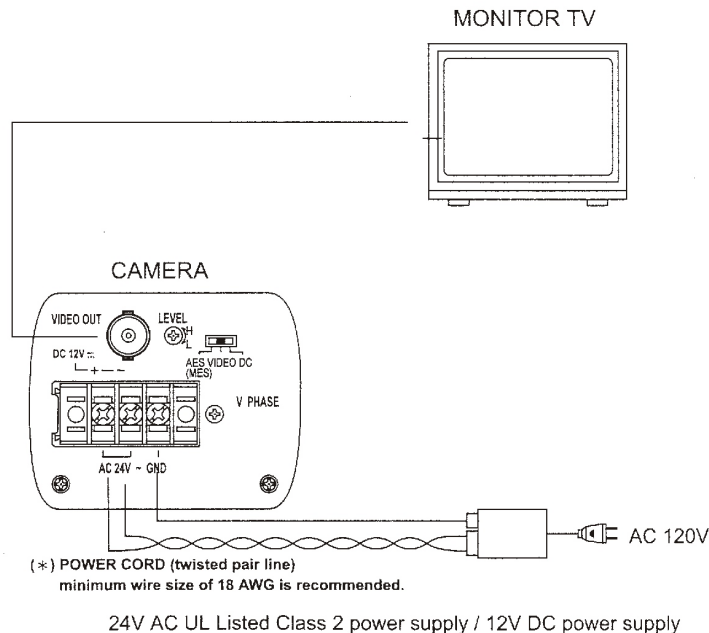

CAUTION : Never input 24V AC and 12V DC at the same time.

### Do not overload power supply

Since this camera uses 24V AC UL Listed Class 2 power supply or 12V DC power supply, it should be connected to a power supply that allows for at least 5w consumption.

### 4-2. Line-Lock Control

- Matching the vertical synchronization with the power frequency is called the Line-Lock.
- This function is activated when the SYNC menu is selected to LL.
- When two or more cameras are switched by the video switcher for viewing by a monitor TV, the vertical sync. phase can be locked with the power frequency, and a stable vertical sync. is obtained without being disturbed at the time of switching.

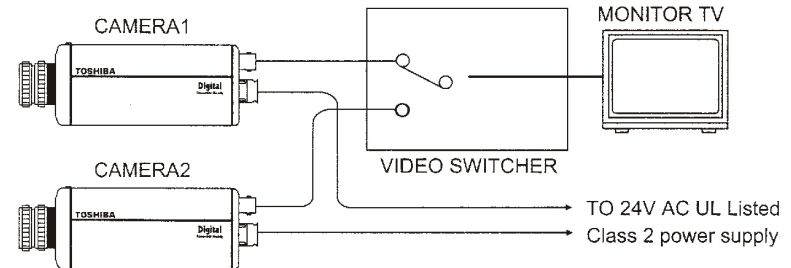

### Note :

- The camera is synchronized to the power frequency of  $60 \pm 1$  Hz covering a normal fluctuation of the power frequency. However, the camera may not cover a large fluctuation caused from the power generated by an engine generator, etc.
- It takes about 10 seconds or more until a stable synchronization is obtained after the power is turned on. This is normal, because several seconds are required to stabilize the camera against power noise.
- Refer to "6. LINE-LOCK PHASE" for adjustment.

### 4-3. Operation

- (1) Mount a lens on the camera and connect equipment. Applicable lenses are specified in Section 5 "LENS"
- (2) Adjust the lens diaphragm and focus for optimum image.



## 5. LENS

### Back-Focus Adjustment

Back-Focus is adjusted at the factory to accommodate most standard lenses. However, at times, slight adjustment to the IK-645A back-focus is necessary.

Mount the Lens to the camera first. Then loosen the Focus Lock Screw. Then rotate the Focus ring until a clear image is achieved. Afterwards, tighten the Focus Lock Screw.

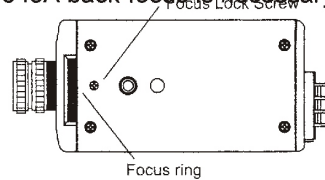

### Note

When the lens weight is more than 1 kg (2.2 lbs), support it on the lens side rather than rely on screw that fix the camera to the tripod.

This camera supports two types of auto-iris lens: Video-type and DC (direct drive) types. Connect the auto-iris connector plug to the IRIS terminal on the side of the camera. Refer to the chart below for correct wiring and set up.

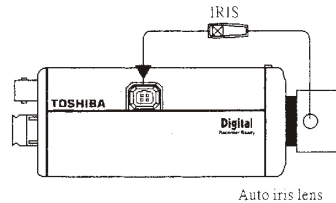

	Video IRIS Lens	Direct Drive IRIS Lens
<b>IRIS terminal pin</b>	1. + 12V	1. Damp- (y)
	2. NC	2. Damp+ (γ)
	3. VIDEO	3. Driver+ (wh)
	4. GND	4. Driver- (g)
<b>IRIS Switch</b>	VIDEO position	DC position

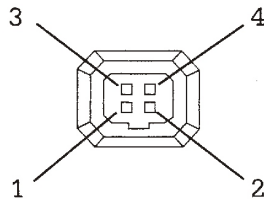

## 6. LINE-LOCK PHASE

If two or more cameras within a system have different AC line phases are switched by the video switcher, the picture on the monitor TV will fluctuate vertically. Connect 24V AC input lines of all cameras so that they all share the same phase. If you still have vertical fluctuation, adjust the V.PHASE controller.

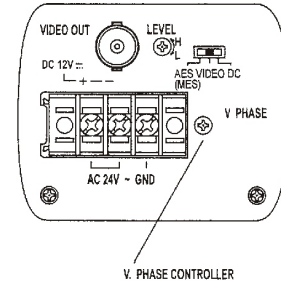

## 7. MENU-DRIVEN SET-UP

The setting menus of hierarchy are shown below and with on-screen character displays.

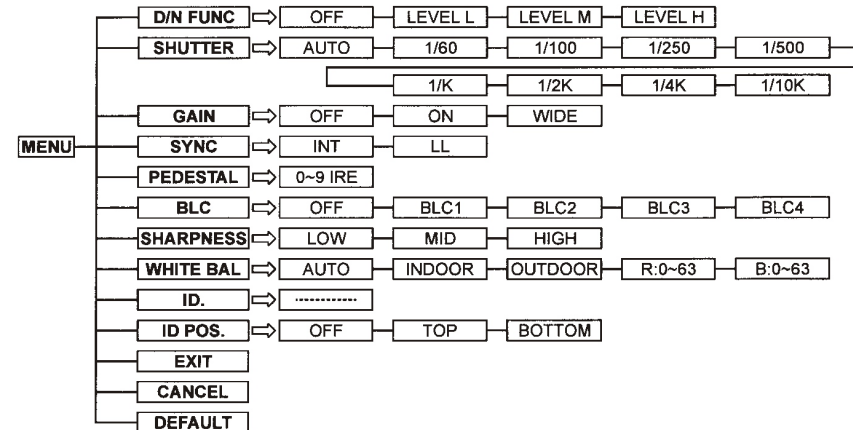

### 7-1. Setting switches and the functions

On the side panel of the cameras there are three push button switches as shown below:

Switch name	Main function
Select	Setting mode call on/off, setting entry
▼	Setting item selection (down)
▲	Setting item selection (up)

## 7-2. Setting mode call and basics

Press the SELECT switch down about 2 seconds then menu will appear on the display. The shaded setting area means an item selected and keeps blinking.

D/N FUNC	LEVEL L
SHUTTER	AUTO
GAIN	ON
SYNC	LL
PEDESTAL	5 IRE
BLC	OFF
SHARPNESS	MID
WHITE BAL	AUTO
NEXT EXIT	CANCEL DEFAULT
ID.	-----
ID POS	OFF
BACK EXIT	CANCEL DEFAULT

### 7-2-1. D/N FUNC (DAY/NIGHT FUNCTION)

Under the low light condition, IK-645A automatically cuts the chroma signal, and displays the clear picture without noise. Move the cursor to the position shown in Fig. Using SELECT switches, to select OFF, LEVEL L, LEVEL M, LEVEL H in the D/N FUNC item.

- A. OFF
- B. LEVEL L: The chroma cut level is set less than 20 to 30 IRE.
- C. LEVEL M: The chroma cut level is set less than 30 to 40 IRE.
- D. LEVEL H: The chroma cut level is set less than 40 to 50 IRE.

"LEVEL H" is for a brighter setting than "LEVEL L".

D/N FUNC	LEVEL L
SHUTTER	AUTO
GAIN	ON
SYNC	LL
PEDESTAL	5 IRE
BLC	OFF
SHARPNESS	MID
WHITE BAL	AUTO
NEXT EXIT	CANCEL DEFAULT
ID.	-----
ID POS	OFF
BACK EXIT	CANCEL DEFAULT

### 7-2-2. Shutter (Exposure time)

Set the slide switch (on rear panel) to AES/ (MES) position. Move the cursor to the position shown in Fig. Using the SELECT switches, choose the shutter speed from AUTO through 1/10K.

AUTO(AES)

Exposure time is controlled automatically within a range of 1/60 sec, to 1/100,000 sec. to obtain an adequate signal. 1/60, 1/100, 1/250, 1/500, 1/K, 1/2K, 1/4K, 1/10K (MES) when the rear panel switch is set to VIDEO or DC the exposure time is fixed 1/60 sec, and shutter mode turn to IRIS.

D/N FUNC	LEVEL L
SHUTTER	AUTO
GAIN	ON
SYNC	LL
PEDESTAL	5 IRE
BLC	OFF
SHARPNESS	MID
WHITE BAL	AUTO
NEXT EXIT	CANCEL DEFAULT
ID.	-----
ID POS	OFF
BACK EXIT	CANCEL DEFAULT

### 7-2-3. GAIN (AGC)

Move the cursor to the position shown in Fig. Using SELECT switches, to select ON, WIDE, OFF.

- A. ON (Standard position, max gain=24dB)
- B. WIDE (High-Sensitivity position, max gain=30dB)
- C. OFF

When using in low light condition, set this item WIDE position.

D/N FUNC	LEVEL L
SHUTTER	AUTO
GAIN	ON
SYNC	LL
PEDESTAL	5 IRE
BLC	OFF
SHARPNESS	MID
WHITE BAL	AUTO
NEXT EXIT	CANCEL DEFAULT
ID.	-----
ID POS	OFF
BACK EXIT	CANCEL DEFAULT

### 7-2-4. SYNC

Move the cursor to the position shown in Fig. Using SELECT switches, to select INT or LL in the SYNC item.

- A. INT : The camera is in the internal SYNC mode.
- B. LL : The camera is in the Line-Lock Mode. Line-Lock phase is set 0 to 300 degree by adjusting the V phase of rear panel. Refer to 4. Connections and Operations.

D/N FUNC	LEVEL L
SHUTTER	AUTO
GAIN	ON
SYNC	LL
PEDESTAL	5 IRE
BLC	OFF
SHARPNESS	MID
WHITE BAL	AUTO
NEXT EXIT	CANCEL DEFAULT
ID.	-----
ID POS	OFF
BACK EXIT	CANCEL DEFAULT

### 7-2-5. PEDESTAL

Move the cursor to the position shown in Fig. Using SELECT switches, to select 0 to 9 IRE in the pedestal items.

D/N FUNC	LEVEL L
SHUTTER	AUTO
GAIN	ON
SYNC	LL
PEDESTAL	5 IRE
BLC	OFF
SHARPNESS	MID
WHITE BAL	AUTO
NEXT EXIT	CANCEL DEFAULT
ID.	-----
ID POS	OFF
BACK EXIT	CANCEL DEFAULT

### 7-2-6. BLC (BACK LIGHT COMPENSATION)

Move the cursor to the position shown in Fig. Using SELECT switches, to select OFF, BLC1, BLC2, BLC3, BLC4. When the automatic electronic iris and auto iris lens used, the exposure adjustment is automatically performed so that a best picture is obtained at next monitor zone. There are 4 ways BLC function for different application. The window area of BLC show as below :

D/N FUNC	LEVEL L
SHUTTER	AUTO
GAIN	ON
SYNC	LL
PEDESTAL	5 IRE
BLC	<b>OFF</b>
SHARPNESS	MID
WHITE BAL	AUTO
NEXT EXIT	CANCEL DEFAULT

ID.	.....
ID POS	OFF
BACK EXIT	CANCEL DEFAULT

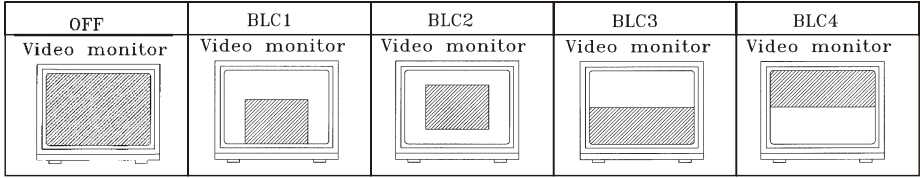

This function is effective when strong light enters the portion other than this zone and auto iris lens closes and darkens the area to view.

### 7-2-7. SHARPNESS

Move the cursor to the position shown in Fig. Using SELECT switches, to select LOW, MID, HIGH in the SHARPNESS items.

D/N FUNC	LEVEL L
SHUTTER	AUTO
GAIN	ON
SYNC	LL
PEDESTAL	5 IRE
BLC	OFF
SHARPNESS	<b>MID</b>
WHITE BAL	AUTO
NEXT EXIT	CANCEL DEFAULT

ID.	.....
ID POS	OFF
BACK EXIT	CANCEL DEFAULT

### 7-2-8. WHITE BAL (WHITE BALANCE)

Move the cursor to the position shown in Fig. Using SELECT switches, to select AUTO, INDOOR, OUTDOOR, MANUAL in WHITE BAL items.

- A. AUTO : The white balance is automatically adjusted corresponding to the color temperature variations on the object. This camera is applicable to color temperature of 2500 to 10K.
- B. INDOOR : The white balance is fixed at color temperatures of 3200" K.
- C. OUTDOOR : The white balance is fixed at color temperatures of 5100" K.
- C. MANUAL : Press the SELECT switch to enter manual set mode. Using ▲▼ button to adjust R Gain & B Gain to have a good white balance, after that press SELECT switch again to leave manual set mode.

D/N FUNC	LEVEL L
SHUTTER	AUTO
GAIN	ON
SYNC	LL
PEDESTAL	5 IRE
BLC	OFF
SHARPNESS	MID
WHITE BAL	<b>AUTO</b>
NEXT EXIT	CANCEL DEFAULT

ID.	.....
ID POS	OFF
BACK EXIT	CANCEL DEFAULT

### 7-2-9. ID. (CAMERA ID.)

Move the cursor to the position shown in Fig. Using SELECT switches, to name each camera up to 16 charactes.

Font list
0,1,2,3,4,5,6,7,8,9
A,B,C,D,E,FG,H,I,J,K,L,M
N,O,P,Q,R,S,T,U,V,W,X,Y,Z
( ) - : / ' , • ■ (SPACE)

D/N FUNC	LEVEL L
SHUTTER	AUTO
GAIN	ON
SYNC	LL
PEDESTAL	5 IRE
BLC	OFF
SHARPNESS	MID
WHITE BAL	AUTO
NEXT EXIT	CANCEL DEFAULT

ID.	.....
ID POS	OFF
BACK EXIT	CANCEL DEFAULT

### 7-2-10. ID POS (CAMERA ID. POSITION)

Move the cursor to the position shown in Fig. Using SELECT switches, to select OFF, TOP, BOTTOM. Show the Camera ID. in monitor screen.

- A. OFF Disappear the Camera ID.
- B. TOP Show the ID position top-left of screen.
- C. BOTTOM Show the ID position bottom-left of screen.

D/N FUNC	LEVEL L
SHUTTER	AUTO
GAIN	ON
SYNC	LL
PEDESTAL	5 IRE
BLC	OFF
SHARPNESS	MID
WHITE BAL	AUTO
NEXT EXIT	CANCEL DEFAULT

  

ID.	.....
ID POS	<b>OFF</b>
BACK EXIT	CANCEL DEFAULT



### 7-2-11. NEXT,BACK

Move the cursor to the position in Fig. Press the SELECT switch, to select the last page or next page.

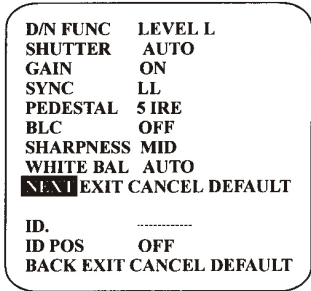

### 7-2-13. CANCEL

Move the cursor to the position in Fig. Press the SELECT switch, exit menu immediately and don't save.

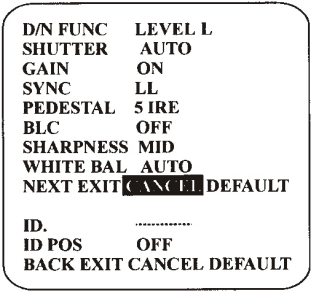

### 7-2-12. EXIT

Move the cursor to the position in Fig. Press the SELECT switch when save all settings and exit.

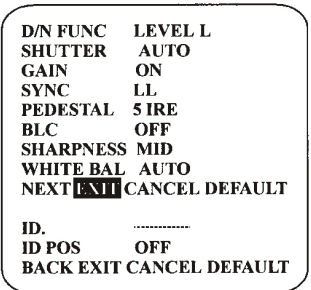

### 7-2-14. DEFAULT

Move the cursor to the position in Fig. Press the SELECT switch to recall the factory settings.

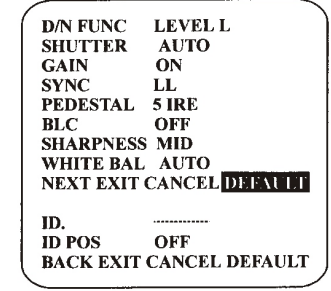
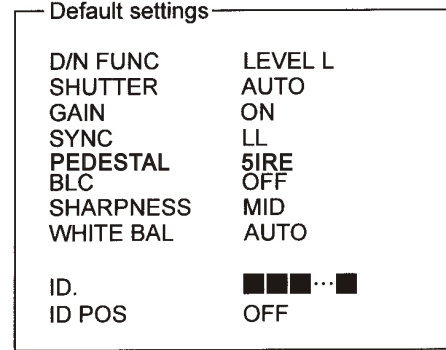

## 8. NOTES ON USE AND INSTALLATION

#### • Do not aim the camera at the sun

Do not aim the camera at the sun or point it at sun even if you are not shooting.

#### • Do not shoot intense light

Intense light such as a spotlight may cause a bloom or smear. A vertical stripe may appear on the screen. However, this is not a malfunction.

#### • Treat the camera with care

Do not drop the camera or subject it to strong shock of vibration. Otherwise, the camera may malfunction.

#### • Never touch internal parts

Do not touch the internal parts of the camera other than the parts specified. Otherwise, the camera may malfunction.

• **Do not splash water on the camera**

Install the camera where the camera can be kept dry. If the camera gets wet, turn off the power and contact your dealer.

• **Install the camera**

**Where no video noise appears**

If cables are wired near electric lighting wires or a TV set, noise may appear in images. In this event, relocate cables or reinstall equipment.

• **Check the ambient temperature and humidity**

Avoid using the camera where the temperature is hotter or colder than specified. Otherwise, the quality of images may deteriorate or internal parts may be affected. Special care is required to use the camera at high temperature and humidity.

• **Should you notice any trouble**

If any trouble occurs while you are using the camera, turn off the power and contact your dealer. If you continue to use the camera when there is something wrong with it, the trouble may much worse and an unpredictable accident may occur.

**9. IN CASE OF PROBLEMS**

Condition	Check Points
No image	<ul style="list-style-type: none"> <li>• Are the camera and connected equipment turned on?</li> <li>• Is the iris of the lens adjusted properly?</li> <li>• Are cables connected correctly?</li> </ul>
Unnatural color	<ul style="list-style-type: none"> <li>• Is the monitor TV adjusted correctly?</li> <li>• Is the lighting too weak?</li> </ul>

**10. EXTERIOR VIEW**

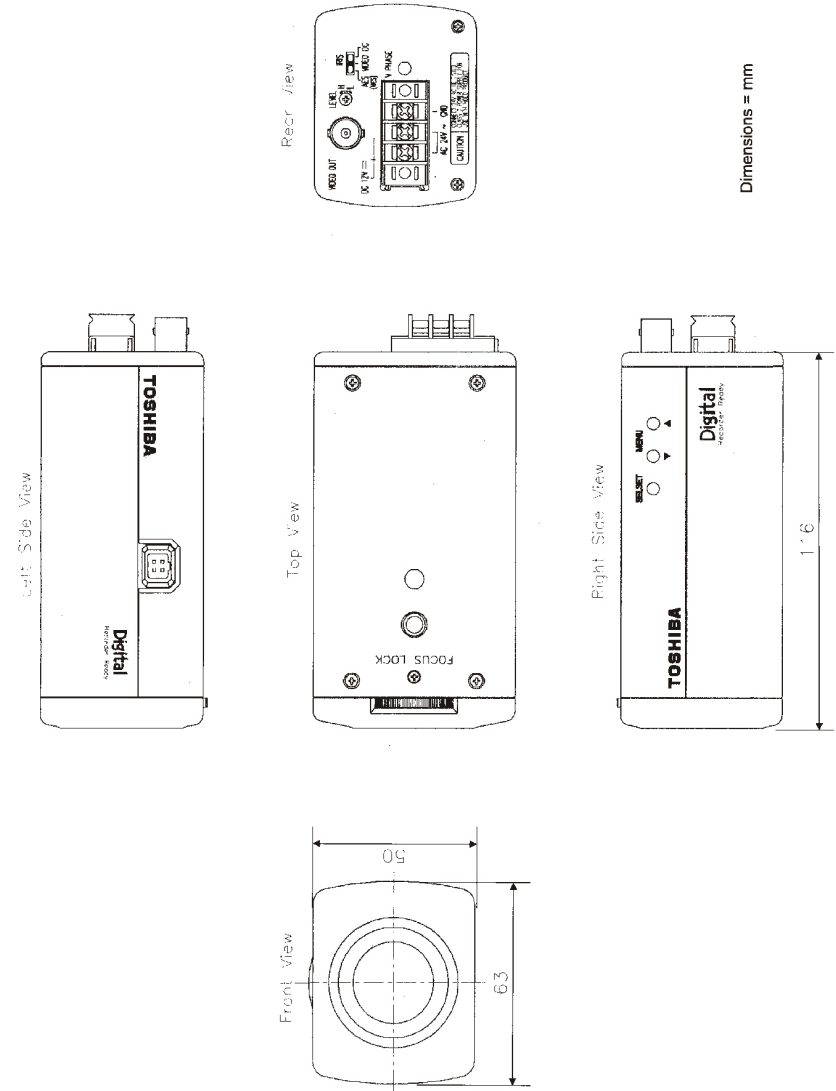

# SECTION 5 SPECIFICATIONS

## 1. SPECIFICAIONS

Power	AC 24V ~ ±10% 60Hz / DC 12V ∴ ±10%
Power consumption	IK-629A, IK-644A: 4.0w (max) with AI lens IK-645A: 4.5w (max) with AI lens
Image sensor	1/3 inch CCD image area sensor
Image pickup area	4.96mm (0.195inch) horizontal x 6.0mm (0.236inch) vertical (1/3inch type)
Effective picture element	IK-629A: 510 horizontal x 492 vertical IK-644A, IK-645A: 768 horizontal x 494 vertical
Scanning system	2 : 1 interlace NTSC Standard TV system
Scanning frequency	15.75kHz horizontal 60Hz vertical
Synchronization	Line-Lock, Internal manually switchable
Resolution	IK-629A: Horizontal 350 TV lines or more Vertical 350 TV lines or more IK-644A, IK-645A: Horizontal 480 TV lines or more Vertical 350 TV lines or more
Minimum illuminance of subject	IK-629A: 0.2 Lux (F1.2, More than 10% of image output $\gamma = 0.45$ ) IK-644A: 0.3 Lux (F1.2, More than 10% of image output $\gamma = 0.45$ ) IK-645A: 0.2 Lux (F1.2, AGC WIDE, More than 10% of image output $\gamma = 0.45$ )
S/N	50 dB or more (AGC off, weight ON)
Video output	VBS 1.0V p-p / 75 ohms, composite
Output impedance	75 $\Omega$ unbalanced
White balance	IK-629A, IK-644A: Automatic (2500.K to 10,000.K) IK-645A: Automatic (2500.K to 10,000.K), PRESET, MANUAL
Iris control	Video Out / Iris Driver Circuit Built in
Gain control	IK-629A, IK-644A: Average AGC, (24dB) IK-645A: Average AGC, On (24dB), Wide (30dB), OFF
Backlight compensation	IK-629A, IK-644A: Manual ON/OFF switching, center-bottom zone light measuring system IK-645A: 4 modes BLC function for different application
Lens mount	CS mount
Ambient temperature	-10°C to + 50°C (14°F to 122°F)
Ambient humidity	30% to 90%
Weight	IK-629A, IK-644A: 450g IK-645A: 500g
External dimensions	2.74(W) x 1.97(H) x 4.56(D) inches (63x50x116mm)
Automatic electronic shutter	ON (1/60s to 1/100000) / OFF (1/60s)